



NORSK POLARINSTITUTT

# RAPPORTSERIE

NR. 84 - OSLO 1993

## R/V LANCE OCEANOGRAPHIC CRUISES, 1993

Cruise 3/93: Barents Sea 2-16 August 1993

Cruise 4/93: Fram Strait and Greenland Sea  
16-30 August 1993

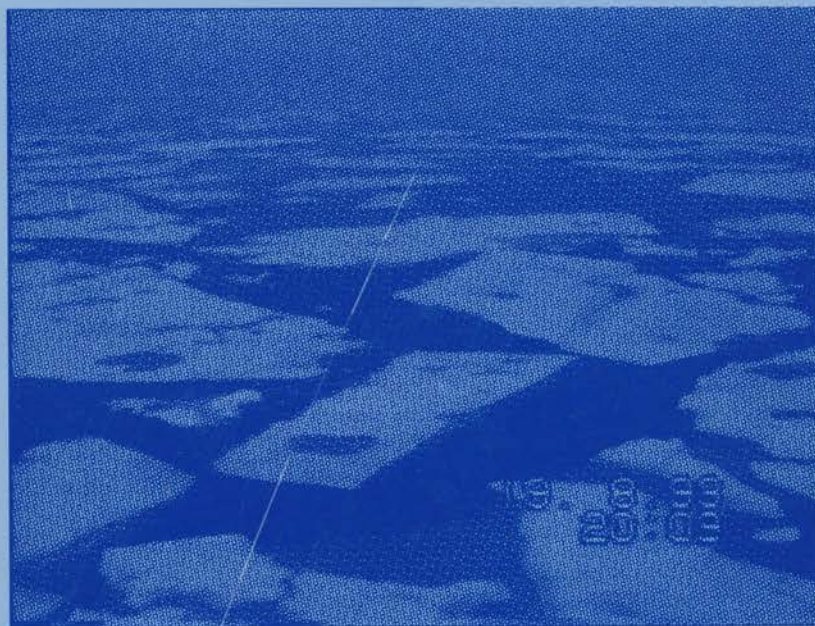



RAPPORT NR. 84

---

**TORGNV VINJE & SVEIN ØSTERHUS (Eds.):**

**R/V LANCE OCEANOGRAPHIC CRUISES,  
1993**

-----

Cruise 3/93: Barents Sea 2-16 August 1993

Cruise 4/93: Fram Strait and Greenland Sea 16-30 August 1993

-----

---

NORSK POLARINSTITUTT  
OSLO 1993

© Norsk Polarinstitut, Oslo  
ISBN 82-7666-073-8  
Printed December 1993

Norsk Polarinstitut  
Middelthuns gate 29  
0301 Oslo, Norway

# Contents

## Page:

- 5 Summary
- 9 Alexander P. Makshtas, Tor de Lange, & Siri M. Kalvig: Air-ice interactions.
- 12 Svein Østerhus, Øyvind Finnekåsa, Tore Furevik, & Helene Moseidjord: CTD-stations and moorings in the Barents Sea.
- 13 Igor Kovtchin and Sergey Unovidov: Acoustic Doppler ice velocity measurements (ADIM)
- 15 Jo Høkedal: Attenuation of UV-b irradiance.
- 18 Torgny Vinje: Sea ice conditions, icebergs and ice maps
- 22 Svein Østerhus, Tobias Böhme, Tore Furevik, & Helene Moseidjord: Mooring work in the Fram Strait and Greenland Sea
- 25 Svein Østerhus, Øyvind Finnekåsa, Helene Moseidjord, Tore Furevik & Einar Nygård: CTD-measurements in the Fram Strait and Greenland Sea
- 26 Hajime Ito & Shinji Morimoto: Greenland Sea water temperatures using XBT, bath thermograph
- 27 Shuhji Aoki, Hajime Ito, & Shinji Morimoto: Air-sea interactions of carbon dioxide in the Greenland Sea
- 28 Megumi Ohta: Phyto-plankton, ice and snow algae in the Greenland Sea
- 29 Fridtjof Mehlum & Morten Bilet: Ornithological observations in the Greenland Sea
- 31 Reinert Korsnes & Jo Høkedal: Sea ice and remote sensing in the Greenland Sea
- 35 ANNEX I: Participants and affiliation.
- 36 ANNEX II : CTD casts.



## SUMMARY

### Objectives

The present cruises are a continuation and expansion of Norsk Polarinstitutt's long term investigation programme on the marine environment in the Arctic. The Institute's marine activities are an integral part of national and international co-ordinated programmes such as the international Arctic Ice Thickness Monitoring Project (AITMP), under the World Climate Research Programme (WCRP), the bilateral Norwegian-Russian Oceanographic Programme (RUSNOP), the international Greenland Sea Project (GSP), and the European Sub-Arctic Oceanographic Project (ESOP) with the Norwegian sub-programme Carbon dioxide Cycles and Deep Water Formation in the Greenland and Norwegian Seas (CARDEEP). The Institute also supports university students with scholarships and allocation of ship time for selected field studies.

### Barents Sea

This year we got permission for the first time under RUSNOP to carry out investigations with a Norwegian ship in the Russian economic zone. Air-ice interaction studies, and water mass mapping between Svalbard and Frans Josef Land were carried out (Fig.1). Because of the special ice conditions, the north-western part of the Barents Sea could not be reached this year. A mooring was deployed east of Edgeøya for long-term monitoring of ice thickness, currents, temperature, and salinity. A test run was made with a moored Russian acoustic device for ice velocity recordings applying the Doppler frequency shift principle. The light conditions in the water column, including the attenuation of the UV-b-radiation, were measured at intervals. Altogether 23 icebergs, ranging from 30 to 200 m across, were observed. Some of them were tabular ones that had drifted south-westwards from Frans Josef Land.

### Fram Strait

The long term monitoring of the northbound warmer water in the West-Spitsbergen Current, and the southbound colder water in the East Greenland Current was continued with CTD-sections across 79°N and 78°N (Fig.2). The sections were connected with CTD-sections across the cold coastal current and further into Kongsfjorden and Isfjorden. In the Fram Strait we retrieved one German and two NP moorings deployed from LANCE in August 1992. Four new NP moorings were deployed to complete an international cross-stream array at 79°N for the monitoring of the fluxes of ice and water from the Arctic Ocean under AITMP and CARDEEP. Ice cores were collected for the study of sediment loads and salinity profiles. A number of video surveys were also made for comparison with ERS-1 SAR uptakes which were ordered for this period.

### Greenland Sea

Having finished the work at 79°N we proceeded southwards along the ice edge, taking CTD-casts at intervals in agreed positions under the GSP. Three German moorings deployed from LANCE in August 1992 at 75°N were retrieved and three new ones deployed under the ESOP and the AITMP. We also recovered one French mooring carrying a signal source for location of constant depth floats, as well as a University of Bergen mooring for monitoring of changes in the bottom water in the Greenland Sea. A CTD-section along the 75th latitude performed previously by the Marine Research Institute, Bergen, under CARDEEP, was completed into the ice in the East-Greenland Current. Thereafter we proceeded with CTD-casts in some of the fixed GSP-positions, and in a zigzag pattern over the fracture zone dividing the Boreas and the Greenland Sea Basins. The conditions in this border area are also of interest for the explanation of special biological and ice distribution features. The CTD-casts indicated that no winter convection with deep water formation had taken place this year in the Greenland Sea Basin

**Torgny Vinje**

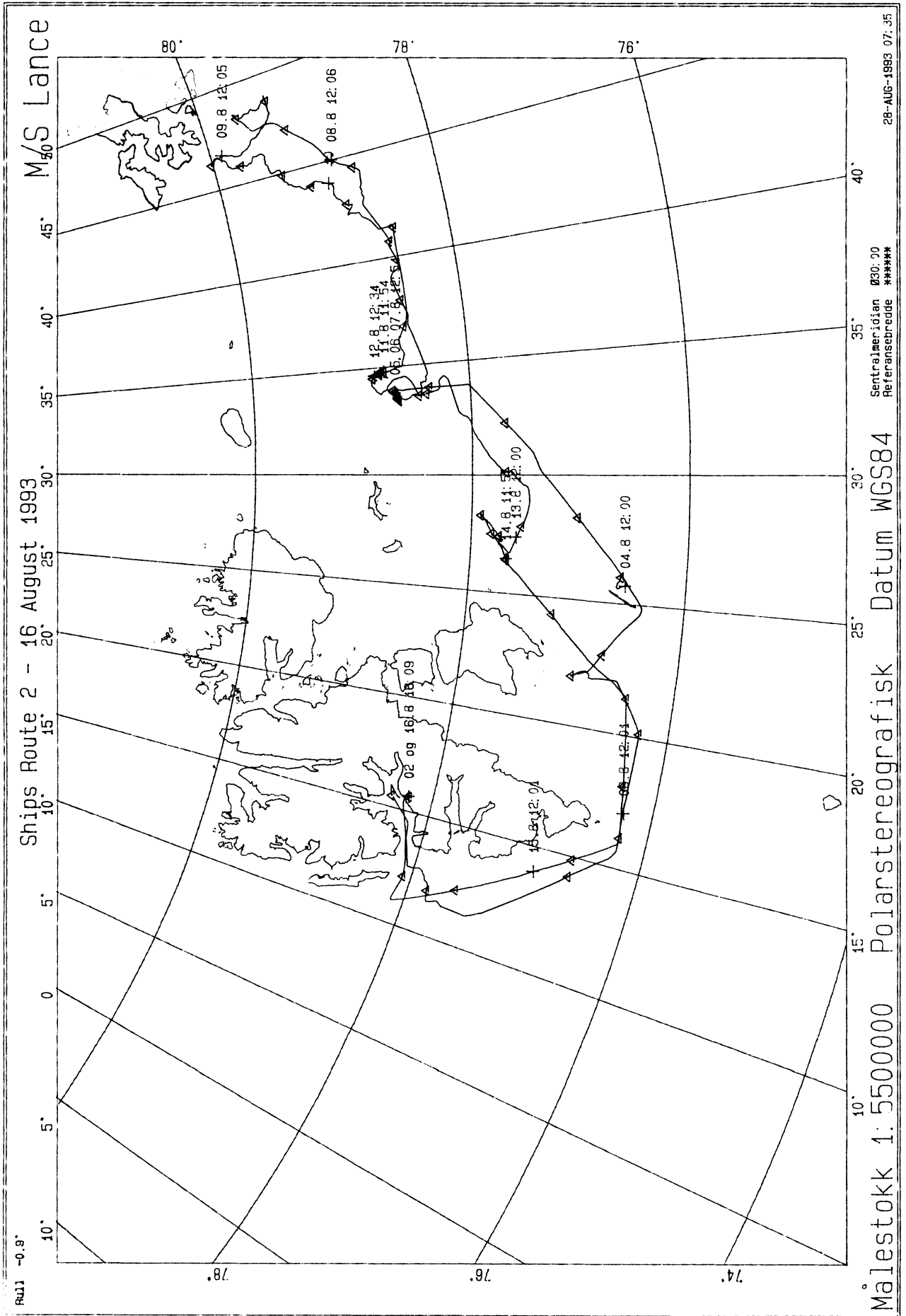

Fig. 1. Ships route Leg 1, 2-16 August 1993.

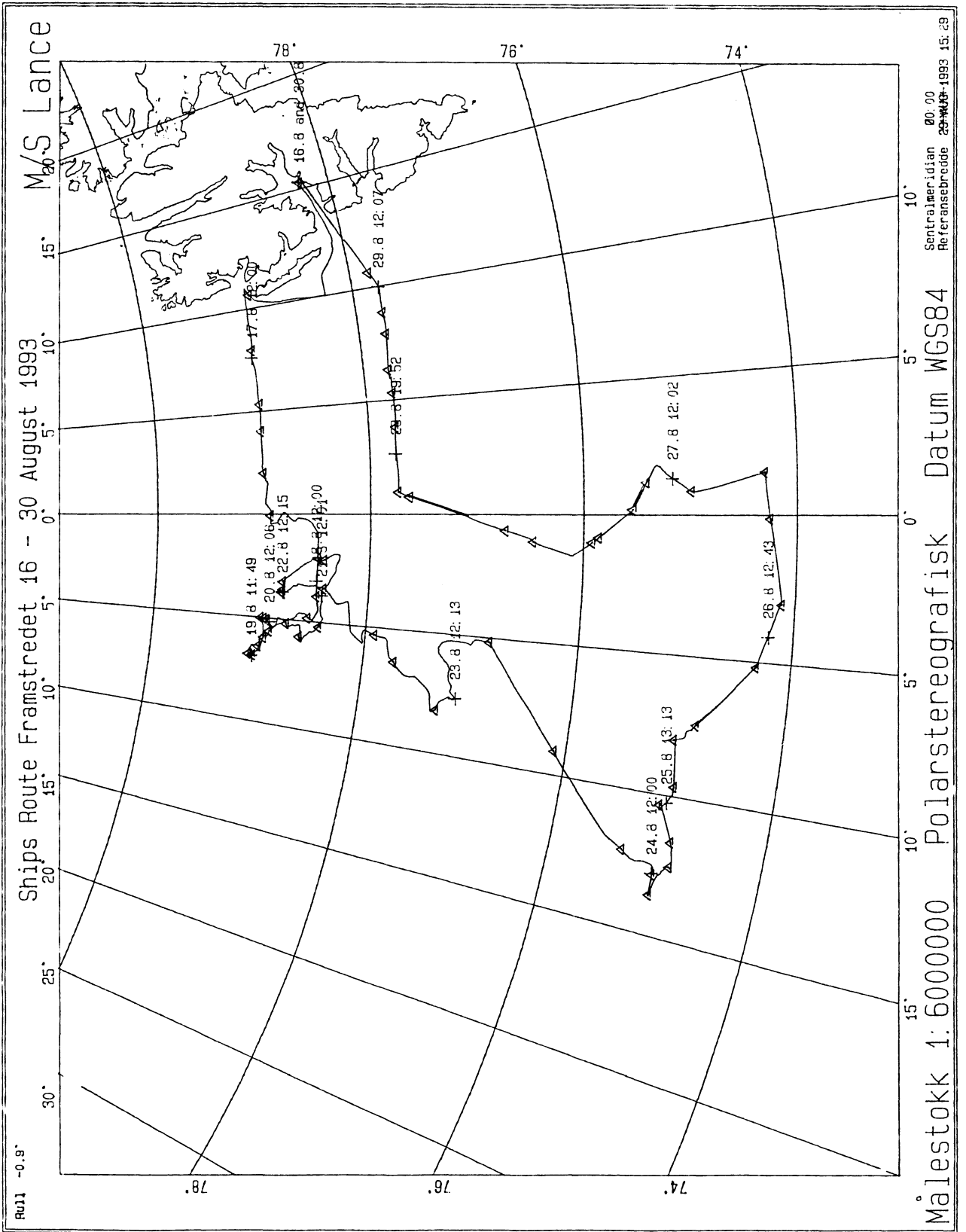

Fig. 2. Ships route Leg II, 16-30 August 1993.





ALEXANDER P. MAKSHITAS, TOR DE LANGE & SIRI M. KALVIG:

## AIR - ICE INTERACTIONS

### Objective

Ice drift due to wind effect is comprised by skin drag, form drag and sail drag. The different effects can be found by using tether sounding equipment, automatic weather stations, and a sonic wind system.

**Ice floe A:** 78.7°N 33.8°E to 78.7°N 33.6°E

Size: approximately 200 × 400 m  
 Ridged multiyear ice with 30% melting ponds  
 Average ridge height: 1m.  
 Freeboard: 20 cm  
 Large surface variability.

	Wind speed	Wind direc.
5/8 1993:	9 - 17 kn.	180°
6/8 1993:	0 - 9 kn.	0° - 10°
7/8 1993:	1 - 7 kn.	0° - 20°

Two automatic weather stations recorded wind speed and temperature at three levels (268 cm, 122 cm, and 40 cm) at 10 minutes intervals. One weather station was used as a reference station and kept at one location. The second was used at three separate locations with different roughness. The sonic wind system was used to measure skin drag at four different locations (also measured at different heights).

The tether sonde was launched 11 times at 3 hours intervals.

**Ice floe B :** 78.7°N 33.8°E

Size: approximately 500 × 300 m  
 Mixture of winter ice and heavily ridged multiyears ice

	Wind speed	Wind direction
11/8 1993:	5 - 15 kn.	150° - 180°

Two automatic weather stations recorded wind speed at three levels and temperature at two levels ( 268 cm, 122 cm, and 40 cm. ) at 10 minutes intervals. One weather station was used as a reference station and kept at one location. The second was used at two locations with different roughness, one in the rough area, and one close to a pond of water. The sonic wind system was used to measure skin drag at three different locations with different heights of the sonic probe.

The tethersonde was launched ten times at 3 hours intervals.

### **Ice floe C: 78.8°N 34.8°E**

Size: approximately 100 × 150 m

Multiyear ice.

Free-board: approximately 30 cm.

	Wind speed	Wind direction
12/3 1993	10 – 16 kn.	100 – 180°

Two automatic weather stations recorded wind speed at three levels and temperature at two levels ( 268 cm, 122 cm, and 40 cm. ) at 10 minutes intervals. The sonic wind system was used to measure skin drag close to one of the automatic weather station; two different heights were used ( 1 m and 2 m. )

### **From the ship**

To estimate the mean aerodynamic roughness for larger area the tethersonde was launched 4 times when the ship were in areas with different ice concentrations.

### **Preliminary result**

The preliminary analysis of the results received on the first ice station, which was placed on a relatively homogeneous ice floe surrounded by ridges and leads showed that the roughness of this floe was at least one order higher than that of ice floes in the Greenland Sea (1) and the ice cover in central Arctic (2).

For ice floes in the Greenland Sea, the mean values of the local roughness, length ( $z_0$ ), and drag coefficient  $C_d$  (10 m) in experiment were:

$$z_0 = 0.0028 \text{ m} = C_d (10 \text{ m}) 2.4 \times 10^{-3} \text{ against } z_0 = 0.00025 \text{ m}, C_d (10 \text{ m}) = 1.4 \times 10^{-3}$$

The comparison of the friction velocities as obtained from profile and eddy correlation measurements in the same place for 32–10 minutes series, showed good agreement in mean values ( $u_{*prof.} = 0.158 \text{ m/s}$ ,  $\sigma_{prof.} = 0.028 \text{ m/s}$ ,  $u_{*cor.} = 0.140 \text{ m/s}$ ,  $\sigma_{cor.} = 0.038 \text{ m/s}$ ) and temporal variability (Fig. 1).

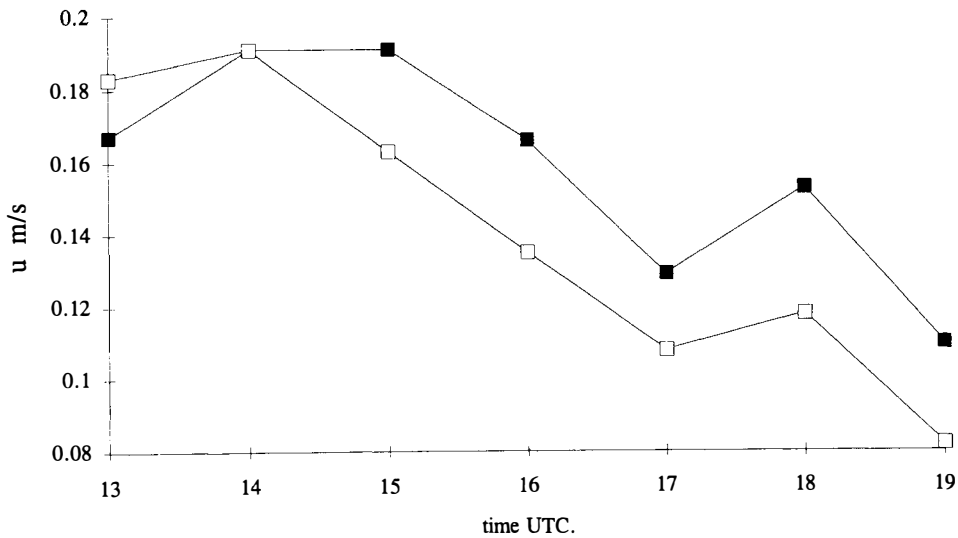

Fig 1. Temporal variability of the friction velocity measured by profile (■) and eddy correlation (□) methods.

It is proposed that the investigations of space in homogeneity of ( $z_0$ ) and  $C_d$ , executed during experiment, when the profile must remained in the same place and the acoustic anemometer was replaced at different distances from it, are representative.

## References

Hansen Bauer, I. & Gjessing, Y.T. 1988: Observations and model calculation of aerodynamic drag on sea ice in the Fram Strait. *Tellus 40A*, 151– 161.

Makshtas A.P. 1991: The heat budget of Arctic ice in the winter. *Arctic and Antarctic Res. Inst. Leningrad*, 1991, 77 p.

SVEIN ØSTERHUS, ØYVIND FINNEKÅSA, TORE FUREVIK, & HELENE MOSEIDJORD:

## CTD STATIONS AND MOORINGS IN THE BARENTS SEA

### CTD MEASUREMENTS

#### Instruments and methods

Vertical temperature and salinity were obtained using a Neil Brown Mark IIIB CTD s/n 01-2826-01 (NP-CTD). The CTD was combined with a General Oceanic Rosette having 12 two-litre Niskin type bottles for water sampling. The temperature sensor was calibrated at the Geophysical Institute calibration facilities before the cruise and will be calibrated after the cruise. For the pressure sensor the calibrations results of the previous cruise were used. During the cruise it was regularly checked against the echo sounder depth and no disagreement was discovered. The conductivity sensor was calibrated against water samples. A total of 57 water samples were analysed on board for this purpose using a Guildline PortSal 8410 salinometer.

The EG&G Ocean Soft-I data acquisition system was used to log the CTD data on a PC.

A total of 56 CTD stations were obtained. In the Barents Sea 33 stations were obtained between Edgeøya and Frans Josef Land. In Storfjorden ten CTD stations were carried out in a section across the Storfjordrenna. A CTD section from the continental slope to the head of Isfjorden was also carried out (Annex II).

#### Moorings

One long time monitoring mooring (NP-93-B1) was deployed in position 77° 55' 16"N, 28° 16' 55"E (Annex II). The mooring was equipped with one CMR-ES300 upward-looking sonar, one Aanderaa RCM current meter, and one Aanderaa WLR pressure sensor.

## ACOUSTIC DOPPLER ICE VELOCITY MEASUREMENTS (ADIM)

A prototype of an Acoustic Doppler Ice Velocity Meter (ADIM) developed at AARI was tested. The instrument has been designed for measuring the two-components ice drift velocity using the Doppler hydroacoustic effect. The observations are stored internally on tape and the operational range is between 100 m and 300 m. The prototype measures at time intervals from 15 sec to 60 min, the frequency is 150 kHz and the present operating time is two months. The weight of the instrument in water is 15 kg.

Tests were performed from LANCE during the periods 5-8 and 11-12 August at 78°52' N and 34°37'E, 25-30 nm from the outer ice border. The water depth in this area is 250-300 m. The ice field consisted of ridged multi-year ice of a thickness between 2.5 and 3 m. The total ice concentration was 90% with a 30% coverage of melt ponds.

The ADIM was lowered in leads with a maximum width of 10 m using a 5 mm thick wire. Measurements of 5 minutes duration were performed at fixed depths between 30 and 250 m (Fig.1) and stored on the internal tape recorder. A direct contact with the instrument was maintained and the signals could also be viewed on board on an oscilloscope in the depth interval 30-130 m. The duration of the acoustic signal was 8 ms using the oscilloscope and 16 ms for the internal storing.

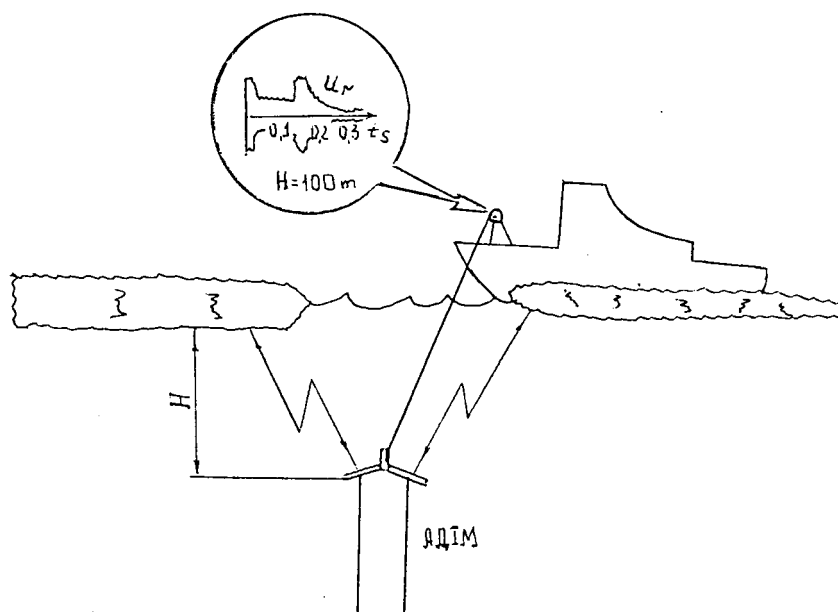

Fig. 1. Experiments from the ship.

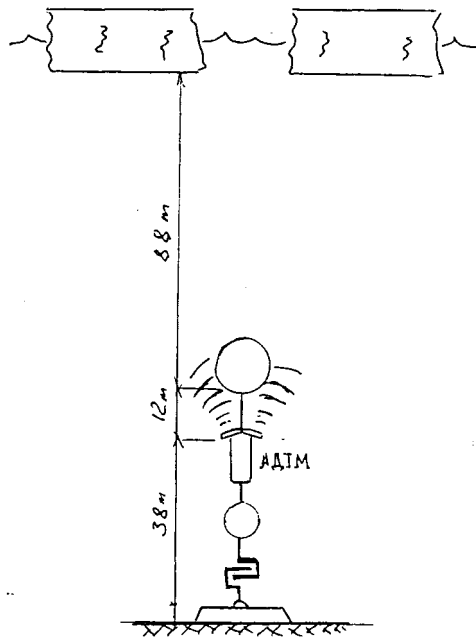

Fig. 2. ADIM mooring.

The tests confirmed that the speed of ice (relative to the ship) could be measured by the prototype. The ADIM transmitter/receiver transducer was improved and protection material was added to eliminate back scatter signals from the bottom during these experiments.

On 14 August the ADIM was attached to a mooring and deployed at  $77^{\circ}44'$  N and  $27^{\circ}24'$  E for eight hours (Fig.2). The ice field consisted of first-year and multi-year ice. The ice thickness varied between 1 m and 3 m, the concentration was 80%, and the ice floes had dimensions between 20 m and 60 m. About 500 measurements were recorded with time intervals of 1 minute during the deployment. Comparison between the ADIM data and the ice drift calculated from wind observations and drift of LANCE revealed standard deviations corresponding to 20% of the observed average velocity and 30% in the observed average drift direction.

Preliminary analysis indicates that data from the ADIM may also be used for detection of open water between the ice floes.

JO HØKEDAL:

## ATTENUATION OF ULTRAVIOLET IRRADIANCE

### Motivation

1. To check out if the relationship between the attenuation of the ultraviolet B (280 - 320 nm) irradiance and other optical properties will be the same as presented earlier (Højerslev & Aas 1991, Høkedal 1993), and increase the observational range.
2. To get a better impression of the optical properties in the northern Barents and Greenland Seas (with special emphasis on the penetration of the UV-b irradiance).
3. To collect samples for testing on new possible relationships.

### Observations.

- UV-b irradiance (306 nm) from the surface to 20-25 meters.
- Blue irradiance (465 nm) from the surface to 20 meters.
- Quanta irradiance (400-700 nm) from the surface to 20 meters.
- Colour-index (450/520 and 450/550) at surface if no waves, and as deeply as possible (10 to 20 meters).
- Secchi-depth on totally twenty-four stations.

### Preliminary results.

*Relation between the attenuation coefficients on UV-b and blue irradiance.* - Neither my earlier presented nor the present observations fit into Højerslev and Aas' relation. On the other hand the coefficients obtained this year fit well into my earlier presented results.

Fig. 1 shows the calculated UV-b attenuation coefficient as a function of the blue one and indicates that not even the observations taken in Atlantic waters fit into Højerslev and Aas' relation.

*The UV-b attenuation coefficient as a function of the colour-index (in 2m).* - Fig. 2 shows a rather good relation between the above parameters. Earlier I have presented a linear relation between the UV-b depth of percentage and the colour index. Due to possible variations of the attenuation coefficient with depth, this one and the depth of percentage can not be freely mixed, however, the indicated trend in the relationship suggests that further analysis should be carried out in this connection.



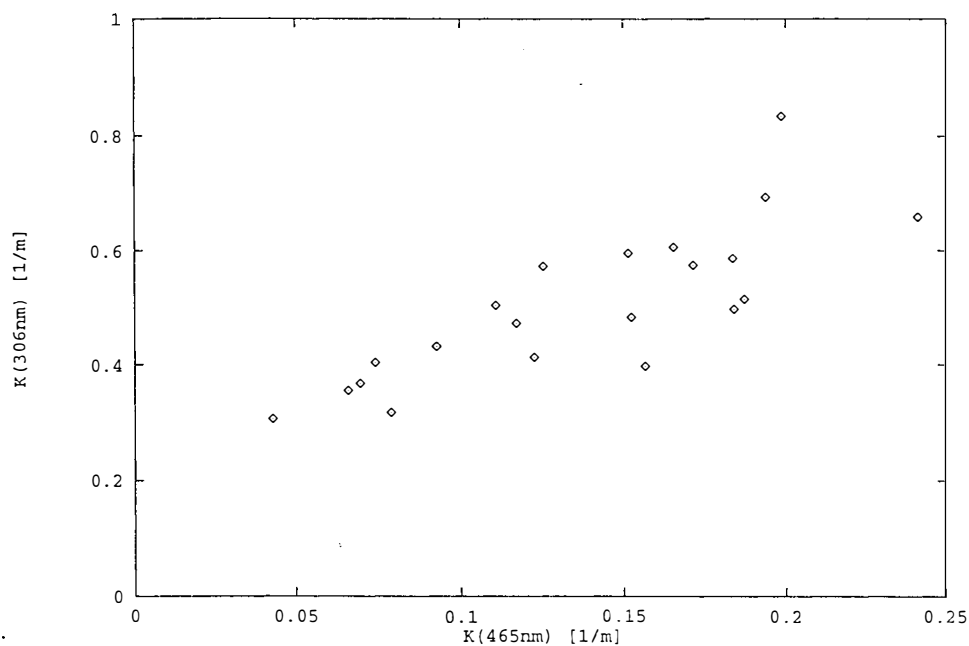

Fig. 1. The attenuation coefficient of the UV-b irradiance (306 nm) (1/m) as a function of the same size for the blue irradiance (265 nm) (1/m).

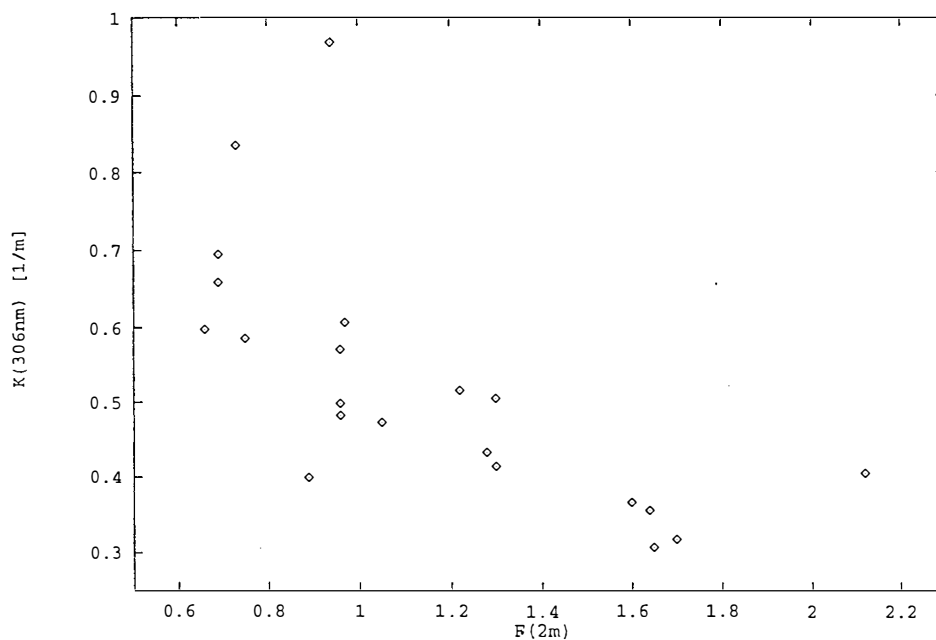

Fig. 2. The attenuation coefficient of the UV-b irradiance (306 nm) (1/m) as a function of the colourindex (450 nm/520 nm) (1) in two metres depth.

## Summary.

The present observations are supporting the previous relations given by Høkedal (1993). On this cruise some "holes" in the earlier data series have been filled, and I also have observed more "extreme" values than last time. Some additional

geographical areas have been covered as well. Especially the observations near the coast of Svalbard may be interesting in this connection.

Unfortunately, there has not been any significant progress in mapping of the UV-b irradiance in the biological important Barents Sea as well as in areas with Atlantic water as defined by Højerslev & Aas 1991.

## References.

Højerslev, N.K. & Aas, E. 1991: A Relationship for the Penetration of Ultraviolet B Radiation Into the Norwegian Sea. *Journal of geophysical research*, 96, 17003 - 17005.

Høkedal, Jo 1993: *Svekninga av nedoverretta UV-b irradians i farvanna rundt Kong Karls Land og i Grønlandshavet. Kalibreringa av et UV-b irradiansmeter.* Institute of Geophysics, University of Oslo. Cand. scient. Thesis.

Torgny Vinje:

## SEA ICE CONDITIONS, ICEBERGS, AND ICE MAPS

Due to a blocking high, centred over the north-eastern part of the Barents Sea during the preceding weeks, a special ice distribution developed in the area this season (Fig.1). The persistent wind pattern caused an increased inflow of ice from the Kara Sea to the eastern part, and an accumulation of ice in the north-western part of the Barents Sea. Between these two drift regions an area of relatively open ice developed, extending north-eastwards to the Frans Josef Land archipelago.

The ice fields consisted of a varying mixture of disintegrating first-year and multi-year ice of thicknesses between 1 m and 3 m. The size of the ice floes varied generally between 20 m and 100 m, depending upon the distance from the ice edge. The ice floes were covered by numerous melt ponds with some melt holes. A varying length of the floe perimeters consisted of sub-surface ice. The melt water ponds and the sub-surface ice amounted in some cases up to as much as 25% of the total floe area.

In the relatively narrow passage up to Frans Josef Land we encountered altogether 23 icebergs, ranging in size from 30 m to 200 m. The freeboard varied between 7 m and 10 m for tabular icebergs and 10 m and 15 m for pinacular ones. One sloping, tabular iceberg measuring 100 m x 100 m and with a height varying between 5 m and 15 m was grounded east of Hopen. This iceberg had been instrumented with an ARGOS buoy last September south of Frans Josef Land under a LANCE-cruise for Operators Committee North. The two meter long stake buoy, initially put into a 2 m drilled hole, was at present nearly melted out of the ice. This indicates the melting rate per year of the surface of an iceberg moving from Frans Josef Land to Spitsbergenbanken.

Through a telefax polling service we received daily ice concentration maps based on the DMSP SSM/I satellite imagery from the Canadian Environmental Service Ice R & D Group, Ottawa (Fig.2). The estimated ice concentration was given in a 25 km x 25 km grid net. These ice maps were of great help to the captain when planning the navigation within, and in and out of the ice fields to the measurement locations. Along the ice edge, however, ice tongues of great hindrance for the navigation were not always indicated on these maps. A daily service is of special importance during the melting season and in areas where changes may occur relatively rapidly due to strong drift.

The great number of melt water ponds, as well as the sub-surface ice along the floe edges, showed up in the ice maps with a lower estimated ice concentration than was actually observed. For navigational purposes this discrepancy is of minor importance as it is the information on the *relative ice concentration* in the neighbouring grid points that is important.

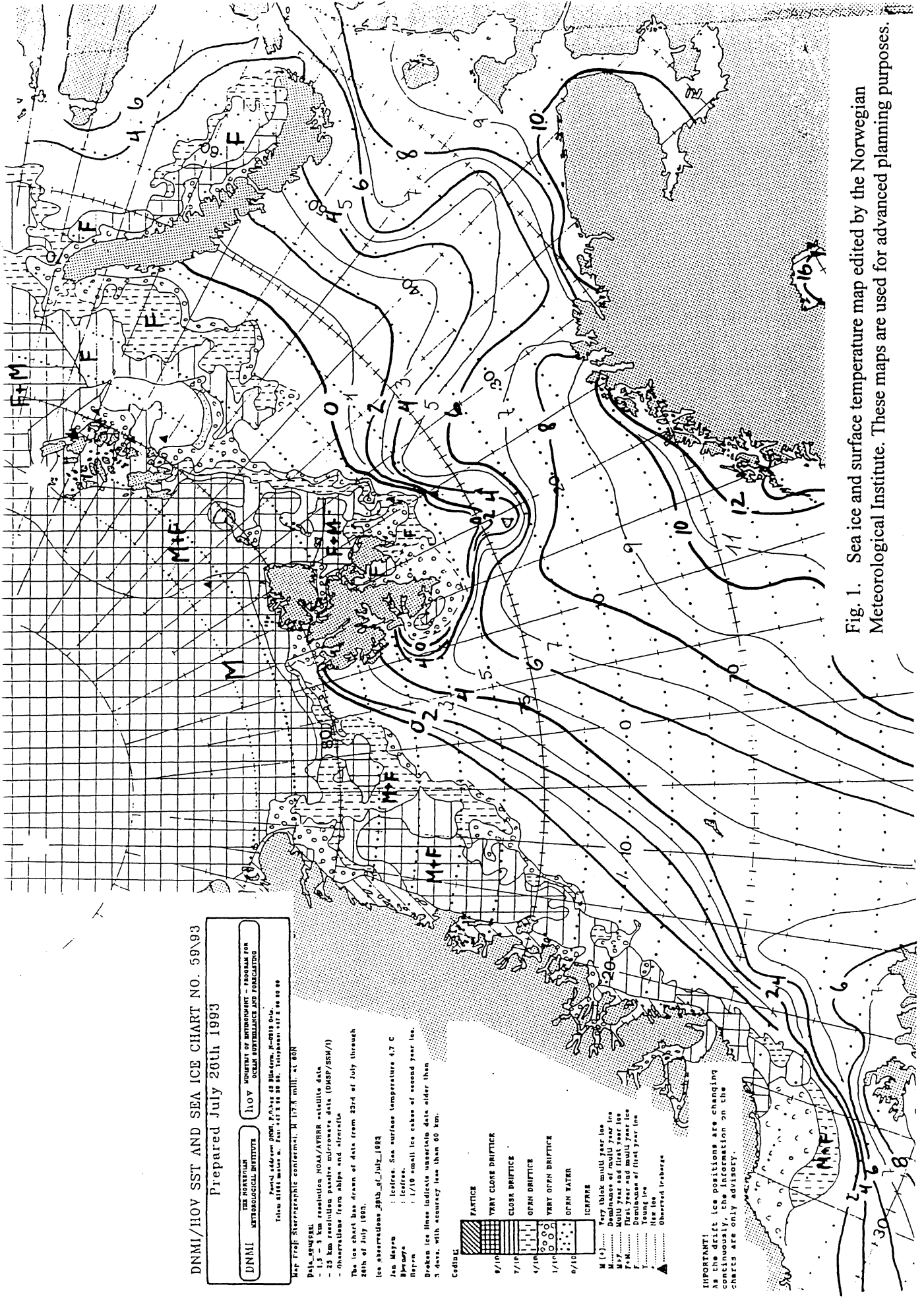

DNMI/HOV SST AND SEA ICE CHART NO. 59.93

Prepared July 20th 1993

DNMI METEOROLOGICAL INSTITUTE

NOV DEPARTMENT OF ENVIRONMENT - PROGRAM FOR OCEAN SURVEILLANCE AND FORECASTING

Track: Arctic area, 60°N - 80°N, 0°E - 360°E

This chart covers the area from 60°N to 80°N, 0°E to 360°E

Map Proj: Stereographic, contour: 1:1000000, at 80N

Data source:  
 - 1.5 - 3 km resolution NOAA/AVRR satellite data  
 - 25 km resolution passive microwave data (DMSP/SSM/I)  
 - Observations from ships and aircraft

The ice chart has been drawn of data from 23rd of July through 28th of July 1993.

Ice observations 28th of July 1993

Jan Mayen : Icefree. Sea surface temperature 4.7 C

Barrow : Icefree.

Bayern : 1/10 small ice cakes of second year ice.

Broken ice lines indicate unsuitable data older than 3 days, with accuracy less than 80 km.

Credits:

- 9/10 FASTICE
- 7/10 VERY CLOSE DRIFTFICE
- 6/10 CLOSE DRIFTFICE
- 5/10 OPEN DRIFTFICE
- 4/10 VERY OPEN DRIFTFICE
- 3/10 OPEN WATER

ICEFREE

M (+) Very thick multi year ice

M (x) Dominance of multi year ice

M (0) Multi year and first year ice

F (x) Dominance of first year ice

F (0) First year ice

Y Young ice

▲ Observed icebergs

**IMPORTANT!**  
 As the drift ice positions are changing continuously, the information on the charts are only advisory.

Fig. 1. Sea ice and surface temperature map edited by the Norwegian Meteorological Institute. These maps are used for advanced planning purposes.

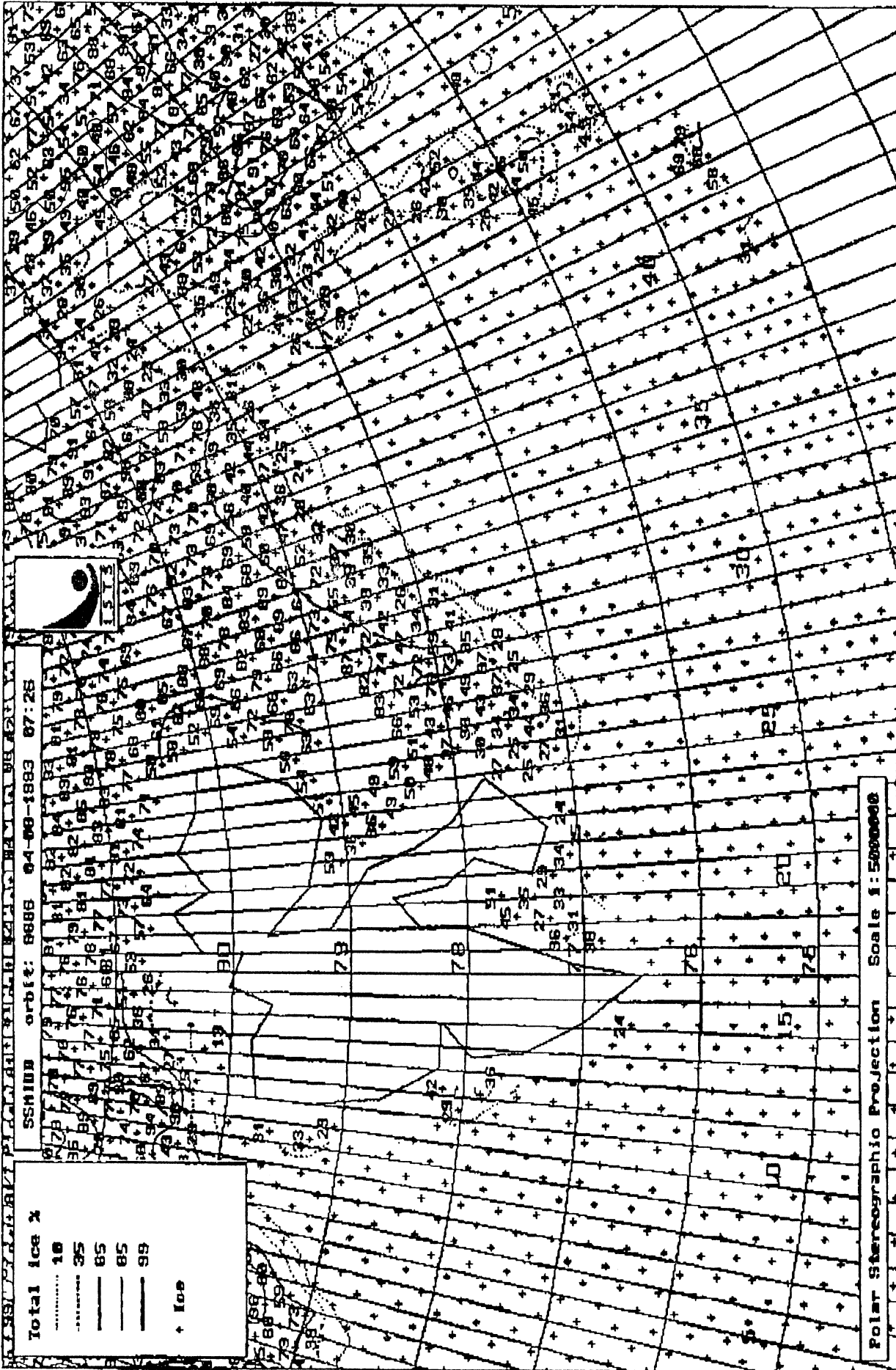

Fig. 2. Sample of Canadian ice concentration map covering the northern Barents Sea. The maps were daily onboard LANCE via a telefax polling service.

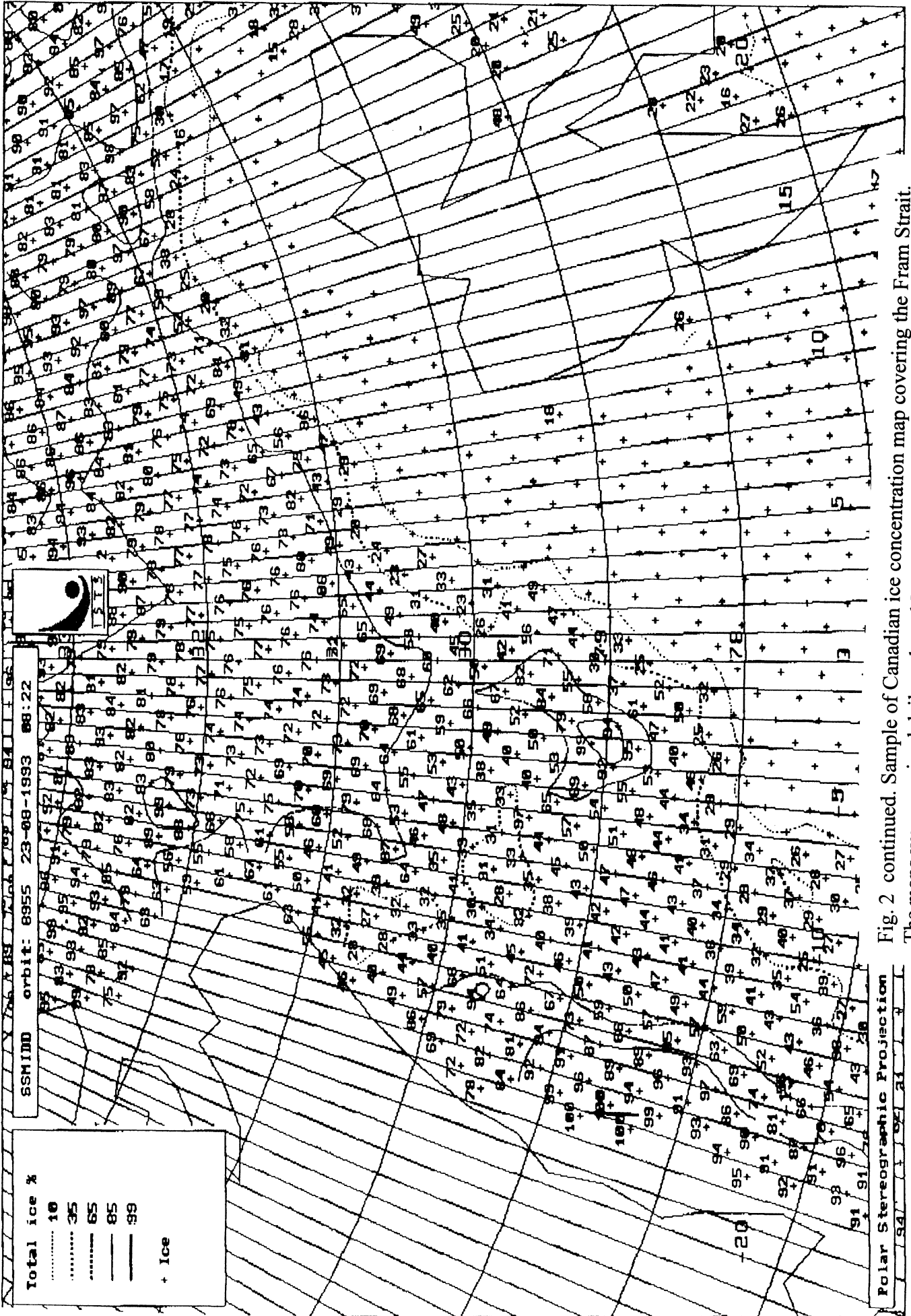

Fig. 2 continued. Sample of Canadian ice concentration map covering the Fram Strait. The maps were received daily onboard LANCE via a telefax polling service.

SVEIN ØSTERHUS, TOBIAS BÖHME, TORE FUREVIK, HELEN MOSEIDJORD  
& EINAR NYGAARD:

## MOORINGS WORK IN THE FRAM STRAIT AND GREENLAND SEA

### Fram Strait

Three moorings, NP-V1-92, NP-V2-92 and M1-92, were recovered in the Fram Strait (Figs. 1 and 2). All three were recovered without problems. The moorings were equipped with CMR-ES 300 upward-looking sonars, Aanderaa current meters, and Mors acoustic release. All instruments had worked satisfactorily throughout the whole measurement period and had 12 months of good data. All these moorings were deployed from LANCE in August 1992 (Østerhus 1993).

Four moorings NP-V1a-93, NP-V1b-93, NP-V2-93, and NP-V3-93 were deployed (Figs 1 and 2). During the deployment of mooring NP-V1-93 the splice of the mooring line broke. For this reason the mooring NP-V1-93 is divided into two parts (a and b).

All moorings in the Fram Strait are part of the AITMP.

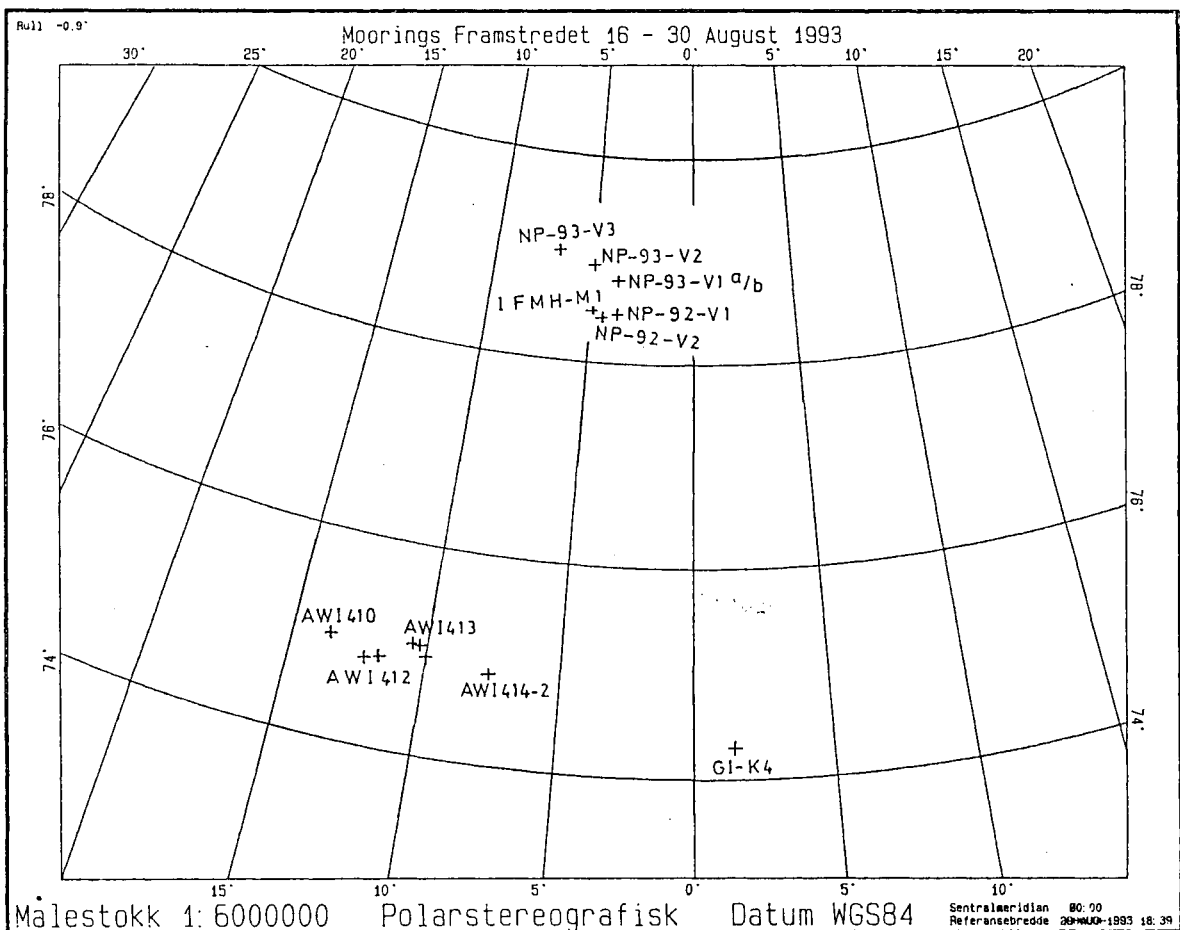
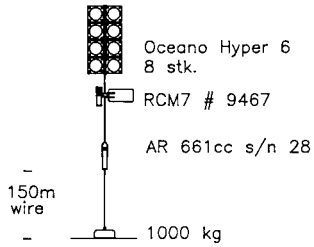

Fig. 1. Mooring names and positions.

NP/93/V1a

POS: N78 49.86 } WGS 84  
 W003 44.60 }  
 Depth: 2085m



NP/93/V1b

POS: N78 48.693 } WGS 84  
 W 3 45.213 }  
 Depth: 2096m

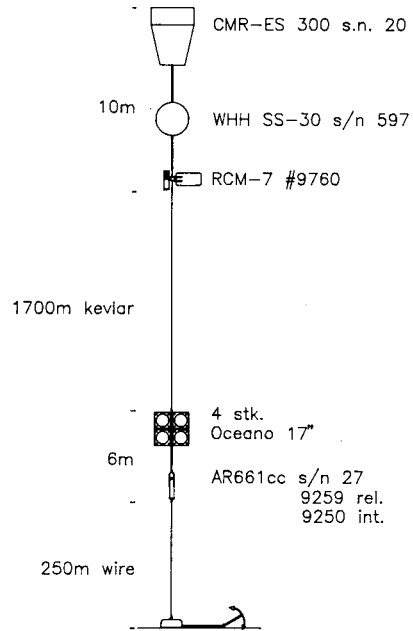

NP/93/V2

POS: N78 57.7 } WGS 84  
 W005 01.5 }  
 Depth: 1261m

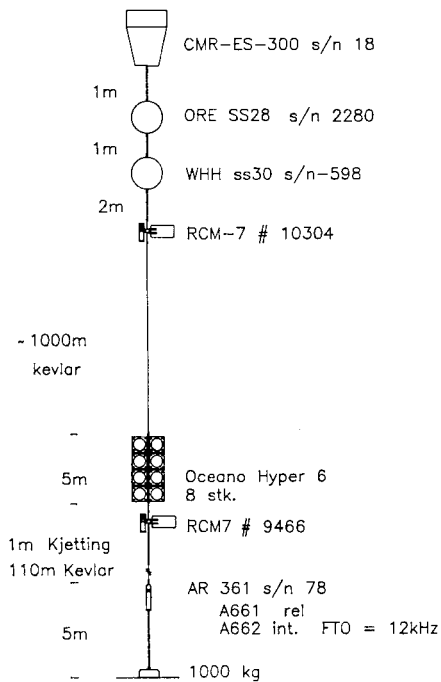

NP/93/V3

POS: N79 04.535 } WGS 84  
 W06 51.615 }  
 Depth: 265m

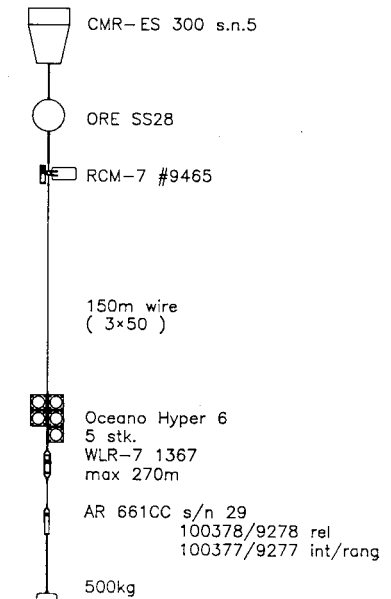

Fig. 2. Moorings deployed in the Fram Strait.



**Table 1. Moorings recovered and deployed in Fram Strait and Greenland Sea**

Name	Latitude	Longitude	Depth	Date deploy	Date recover
NP-V1-92	N78°29.69'	W03°41.75'	2076	27.08.92	18.08.93
NP-V2-92	N78°27.54'	W04°24.27'	1236	26.08.92	18.08.93
IFMH-M1-92	N78°31.301'	W04°54.935'	515	25.08.92	18.08.93
NP-V1a-93	N78°49.86'	W03°44.60'	2109	21.08.93	
NP-V1a-93	N78°48.673'	W03°45.213'	2096	21.08.93	
NP-V2-93	N78°57.75'	W05°01.5'	1261	20.08.93	
NP-V3-93	N79°04.535'	W06°51.615'	265	19.08.93	
AWI 410	N75°00.084'	W13°35.534'	198	16.08.91	24.08.93
AWI 412-2	N74°52.939'	W11°43.015'	2362	21.08.92	25.08.93
AWI 413-2	N75°03.579'	W10°16.310'	3140	21.08.92	25.08.93
AWI 414	N75°00.17'	W07°59.59'	3400	20.08.92	
AWI 412-3	N74°50.638'	W12°13.89'	1580	24.08.93	
AWI 413-3	N75°03.488'	W10°32.878	3075	25.08.93	
AWI 414-2	N74°52.693'	W07°37.668'	3425	26.08.93	
LODYC-G3	N74°57.55'	W10°00.10'	3226	07.04.93	26.08.93
GI-K4	N74°18.356'	E01°28.834'	3737	25.08.91	27.08.93

## Greenland Sea

In the Greenland Sea at 75°N three moorings (AWI 410, AWI 412-2 and AWI 413-2) were recovered (Fig. 2). All the moorings were equipped with Aanderaa current meters and Mors acoustic releases. One was equipped with CMR ES300 upward-looking sonar and one with APL upward-looking sonar. The acoustic release on the AWI 410 mooring did not respond and the mooring was recovered by means of dredging.

One mooring, AWI 414, was located but the release did not work. After consulting AWI it was decided not to try dredging the mooring.

One mooring, LODYC-G3 owned by Laboratoire D'Océanographie Dynamique et de Climatologie, was recovered in position N74°57.55', W10°00.10'. This mooring was equipped with a sound source, ARGOS beacon, and Mors acoustic release.

One mooring, GI-K4 owned by the Geophysical Institute, Bergen, was recovered in position N74°18.35', W01°28.83'. This mooring was equipped with two Aanderaa RCM8 current meters and Mors acoustic release.

## References

Østerhus, S. (Ed.) 1993: Cruise Report 1992. R/V Lance, Greenland Sea and Fram Strait. *Norsk Polarinstitutt Rapport Nr. 82*.

## CTD MEASUREMENTS IN THE FRAM STRAIT AND THE GREENLAND SEA

### Equipment and techniques

Temperature and salinity profiles were obtained using a Neil Brown CTD, MKIII B s.n. 01-2826-01 (NP-CTD). The CTD was combined with a General Oceanic Rosette having 12 two-litre Niskin type bottles for water sampling. The temperature sensor was calibrated at the Geophysical Institute calibration facilities before the cruise and will be calibrated after the cruise. One SIS (Sensoren Instruments Systeme) reversing thermometers was used to check the CTD temperature in the field. Water samples were taken for onboard analysis of salinity. A Guildline Instruments Salinometer (PortaSal, model 8419 s.n. 59721) was used for salinity analysis of 200 water samples. The PortaSal salinometer was regularly (daily) calibrated against IAPSO Standard Sea water batch P108. The salinometer was stable during the whole period. The CTD pressure sensor was checked against the echo sounder, one SIS pressure sensor, and compared with results from previous cruise.

### Field work

A total of 55 CTD stations were obtained in the Fram Strait and the Greenland Sea, (Annex II). One section was taken across the Fram Strait at 79°N, one was taken across the Greenland Basin at 75°N, and one across the West Spitsbergen Current west of Isfjoden. Water samples were taken for numerous biological and chemical analyses (see M. Ohta, p. 28, in this report).

HAJIME ITO & SHINJI MORIMOTO (NIPR):

## **GREENLAND SEA WATER TEMPERATURE FROM XBT BATH THERMOGRAPH**

Temperature profiles are obtained at 84 points on route.

Instrument: Tsurumi-Seiki Co., Ltd.  
Converter MK-30  
Probe T-5, T-6, T-7  
Scheme: Every 30 minutes (longitude) / 10 minutes (latitude), except at  
the CTD stations  
Depth: Maximum depth is 1800 m  
Data access: All the data will be deposited at Norsk Polarinstitut (attn.  
Østerhus), after they are converted to IBM format.

## AIR-SEA INTERACTIONS OF CARBON DIOXID IN THE GREENLAND SEA

### PCO<sub>2</sub> Measurements of surface sea water

Air samples equilibrated with surface sea water were collected:

1.	79.01N	8.55E	2.79.00N	5.59E	3. 79.00N	3.59E
4.	79.00N	1.59E	5.78.29N	2.00W	6. 78.30N	3.16W
7.	78.29N	3.48W	8.78.31N	4.57W	9. 78.59N	5.04W
10.	78.50N	3.45W	11.78.01N	5.44W	12. 77.01N	5.20W
13.	75.00N	13.35W	14.74.56N	12.47W	15. 74.53N	11.43W
16.	75.04N	10.20W	17.74.59N	9.00W	18. 75.02N	8.01W
19.	74.20N	5.11W	20.74.08N	2.60W	21. 74.18N	1.28E
22.	75.00N	0.50E	23.75.20N	1.50E	24. 75.35N	0.02E
25.	76.05N	1.31W	26.77.08N	0.01E	27. 77.45N	1.00E
28.	77.45N	3.48E				

### Measurements of dissolved inorganic carbon content

Water samples were collected by a NISKIN sampler.

	Lat.	Long.	Depth (m)
1.	79.00N	8.55E	200, 175, 150, 125, 100, 75, 50, 25, 10
2.	79.00N	8.00E	1000, 800, 600, 400, 200, 100, 75, 50, 25, 10
3.	79.00N	5.59E	1900, 1600, 1200, 800, 400, 200, 100, 50, 25, 10
4.	79.00N	4.01E	2600, 1900, 1200, 800, 400, 200, 100, 50, 25, 15
5.	79.00N	1.59E	2400, 1800, 1300, 800, 400, 200, 100, 50, 25, 10
6.	78.56N	0.00	2400, 1800, 1300, 800, 400, 200, 100, 50, 25, 10
7.	78.30N	3.16W	2380, 2096, 1800
8.	78.29N	3.48W	1800, 1200, 800, 400, 200, 100, 50, 25, 10
9.	78.31N	4.57W	400, 200, 100, 50, 25, 10
10.	79.03N	6.53W	200, 100, 50, 25, 10
11.	74.55N	12.36W	1100, 700, 400, 200, 100, 50, 25, 10
12.	75.04N	10.22W	3080, 2400, 1800, 1300, 800, 400, 200, 100, 50, 25, 10
13.	74.59N	9.00W	3200, 2400, 1600, 800, 400, 200, 100, 50, 25, 10
14.	74.20N	5.11W	3497, 2500, 1600, 800, 400, 200, 100, 50, 25, 10
15.	74.08N	3.00W	3500, 2500, 1600, 800, 400, 200, 100, 50, 25, 10
16.	74.18N	1.28E	3500, 1800, 800, 400, 200, 100, 50, 25, 10
17.	75.00N	0.50E	3761, 2500, 1600, 800, 400, 200, 100, 50, 25, 10
18.	75.20N	1.50E	2800, 1600, 800, 400, 200, 100, 50, 25, 10

MEGUMI OHTA:

## **PHYTO-PLANKTON, ICE AND SNOW ALGAE IN THE GREENLAND SEA**

### **Introduction**

The aim of my work was to collect water samples mainly for identification of flagellate species from the Fram Strait. The Fram Strait region is the major site of outflow of Arctic water and ice. Cold Arctic water and warm Atlantic water are also mixed together here. It would be interesting, therefore, to see the possible distributions of these organisms in Atlantic water masses. Several articles/papers show the importance of flagellates (swimming phyto-plankton without thick cellwalls made of cellulose, silisium or calsium), as primary producers from different places of the world, so as from polar waters. Anyway, little is known concerning taxonomy of the flagellates.

### **Materials and methods**

Water was collected from the Fram Strait region along 79°N. Vertical profiles of temperature and salinity were collected using EG & G Ocean Soft I Programme. Water samples collected, using Rosette-mounts principally from 0 to 100 m, were kept in 250 ml medicin bottles and fixed with 25% glutaraldehyd and 25% paraformaldehyd. Samples were also collected by a landing net (mask size 20 µm and 5 µm). Ice algae and algae on the snow were collected when possible. Special samplings for coccolithophorids (algae with CaCO<sub>3</sub>-cellwalls) were made.

### **Cultivation of collected samples**

Fixed samples will be taken to the University of Oslo for examination by transmission-electronmicroscopy. Most of the flagellates will be between 2 and 20 µm, and magnification up to 10 - 30 000x is necessary. These samples may also contain new, yet not registered species.

FRIDTJOF MEHLUM & MORTEN BILET:

## ORNITHOLOGICAL OBSERVATIONS IN THE GREENLAND SEA

### Objectives of study

Large numbers of seabirds are found in the Greenland Sea and the Fram Strait region (Mehlum 1989). It is believed that most of these birds breed along the western coasts of Spitsbergen. The different species have their own habitat preference at sea. Previous studies in Svalbard waters and elsewhere have shown that seabird distributions at sea are often associated with physical features which concentrate prey or make prey more easily available to seabirds. These features might be frontal zones between different water masses, eddies, ice-edges, coastal upwelling zones and shelf-breaks. The main task of the present study was to collect supplementary data on seabird distribution in the area and correlate these distributions with physical oceanographic and bathymetric features.

### Materials and methods

The abundance of seabirds was recorded by standardized transect methods (Tasker et al. 1984). A 300 m standard transect width was applied. The observations were entered directly (real time) into a pen computer (Grid). All birds observed within the transect were recorded. A Visual Basic computer programme was made for coding the observations and for minimizing the handling time of each observation. The computer clock was synchronized with the ships main clock. The ship's geographical position (GPS-system) was entered to the field computer every 1/2 - 1 hour during periods with steady course and speed, and otherwise upon changes in speed or direction. An East-West transect was conducted at 79°N, from the coast of Spitsbergen and into the marginal ice zone in the Fram Strait. Several transects were made within the Marginal ice zone, as well as several crossings of the outer ice-edge. A ca 330 km long transect was made just East of the ice-edge from 77°13'N, 05°15'W to 75°00'N, 13°35'N. The rest of the cruise was conducted in ice-free waters, and comprised a West-East transect at 75°N and a northward transect in the central Greenland Sea, followed by a West-East transect at 78°N towards Isfjorden.

## Preliminary results

The main species of interest were alcids (Alcidae). The Little Auk (*Alle alle*) and the Brünnich's Guillemot (*Uria lomvia*) dominated by numbers. Similar to what has been recorded on previous cruises west of Spitsbergen there was a peak in Brünnich's

### 10-min periods, Little Auks, 23-24 AUG. 1993

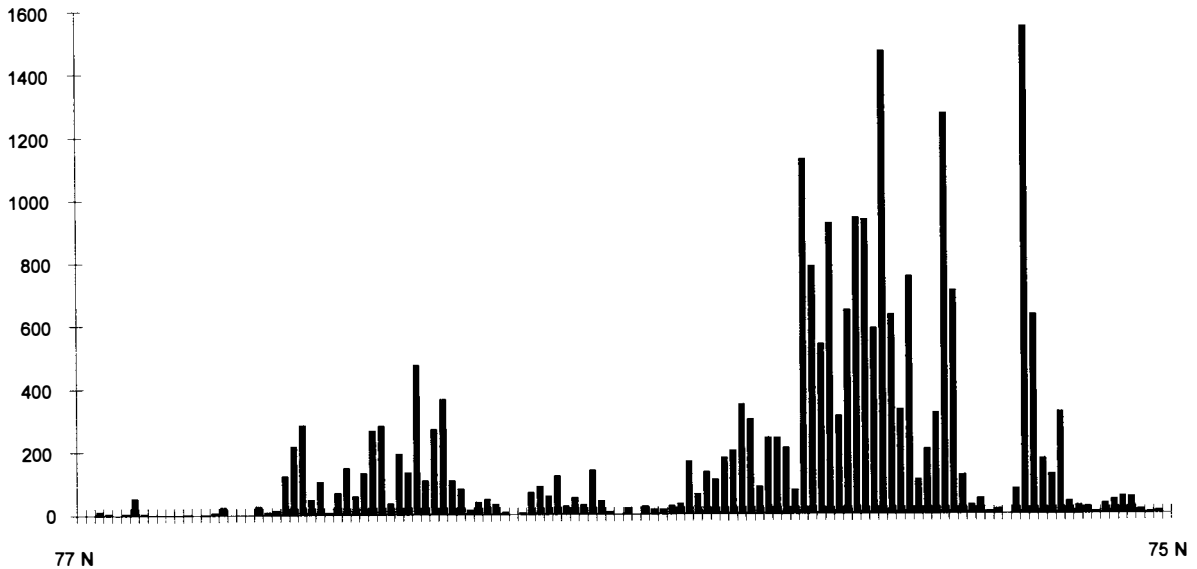

Fig. 1. Number of Little Auks (*Alle alle*) observed during the transect from 77 to 75°N. The data are aggregated into 10-minute observation intervals.

Guillemot numbers at the shelf break at the 79°N transect. Farther West the numbers decreased rapidly to background level. In contrast, the Little Auk was abundant at the ice edge and in ice covered waters. On the latitudinal transect at 75°N Little Auks were abundant only in the western part, supporting the hypothesis of a SW migration of Svalbard birds. Brünnich's Guillemots were low in numbers, but most observations were made generally more to the south than in the case of Little Auks. Parents with young were seen in the southwestern part of the study area, which support the existing ringing data showing that the main wintering area for Svalbard birds is in SW Greenland.

## References

Mehlum, F. 1989: Summer distribution of seabirds in northern Greenland and Barents Seas. *Norsk Polarinstitutt Skrifter* 191, 1-56.

Tasker, M.L., Hope Jones, P., Dixon, T. & Blake, B.F. 1984: Counting seabirds at sea from ships: a review of methods employed and a suggestion for a standardized approach. *Auk* 101, 567-577.

R. KORSNES & J. HØKEDAL:

## SEA ICE AND REMOTE SENSING

A small sea ice programme was carried out in the Fram Strait. An ERS-1 SAR coverage was obtained on 19 August (Figs. 1 and 2), and some surface ice samples (Tables 1, 2, and 3) as well as video images (Fig. 3) were collected for later comparison with the SAR return signal structure.

Ice corings were made at three locations:

Station #	Time/Date (Aug 1993)	Position (deg)		Ice type	Size (m <sup>2</sup> )
		Lat	Long		
1	11:30 18	N 79 02.83'	W 6 52.68'	MY	200 x 500
2	10:30 20	N 78 59.007'	W 5 03.869'	MY	1000 x 700
3	10:18 22	N 78 49.5'	W 3 43.99'	MY	70 x 60

Ice samples were taken from each core at about 20 - 30 cm intervals, and stored in bottles supplied with identification numbers (tables 1 - 3) for later analyses of salinity, yellow material, and algae content.

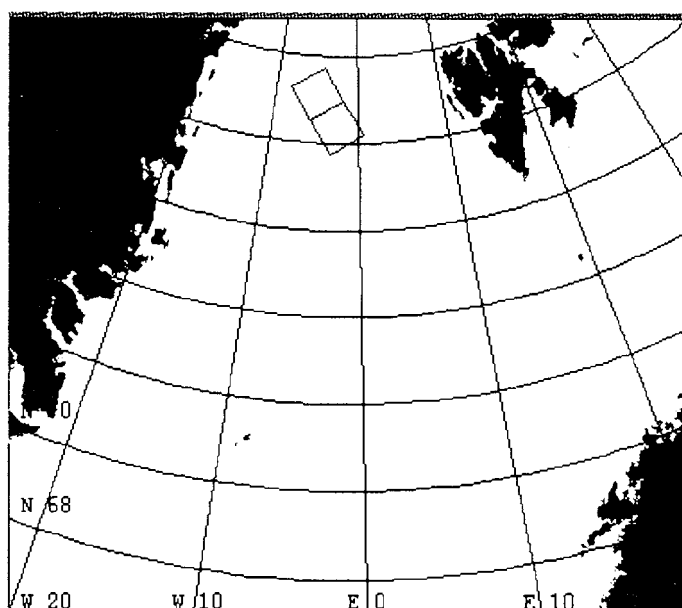

Fig. 1. ERS-1/SAR swath 19 August at 20:42.



Table 1: Coring on Ice Station #1

Depth (cm)	Bottle #
Hole # 1:	
10 - 15	5
40 - 46	6
67 - 72	7
80 - 84	8
Hole # 2:	
10 - 13	9
33 - 37	10
62 - 66	11
83 - 87	12
Hole # 2:	
10 - 13	13
35 - 39	14
65 - 70	15
87 - 90	16

Table 2. Coring of Ice Station # 2

Depth (cm)	Bottle #
Hole # 1:	
10 - 14	17
35 - 39	18
65 - 69	19
86 - 90	20
114 - 117	21
140 - 144	22
160 - 164	23
180 - 184	24
Hole # 2:	
10 - 14	25
36 - 40	26
64 - 68	27
92 - 96	28
119 - 123	29
141 - 145	30
180 - 183	31
210 - 213	32

Table 3. Coring on Ice Station # 3.

Depth (cm)	Bottle #
Hole # 1:	
14 - 20	33
40 - 44	34
55 - 60	35
80 - 84	36
100 - 105	37
122 - 126	38
141 - 145	39
160 - 163	40
180 - 184	41
196 - 200	42
220 - 224	43
247 - 251	44
267 - 271	45
295 - 300	46
310 - 314	47
330 - 333	48
356 - 360	49

Depth (cm)	Bottle #
Hole # 2:	
12 - 15	50
30 - 34	51
54 - 58	52
75 - 79	53
95 - 99	54
116 - 120	55
131 - 135	56
157 - 161	57
175 - 179	58
196 - 200	59



Figure 2: ERS-1 SAR image 19 August at 20:42 GMT. The circle marks the Lance position (cf Figure 3).

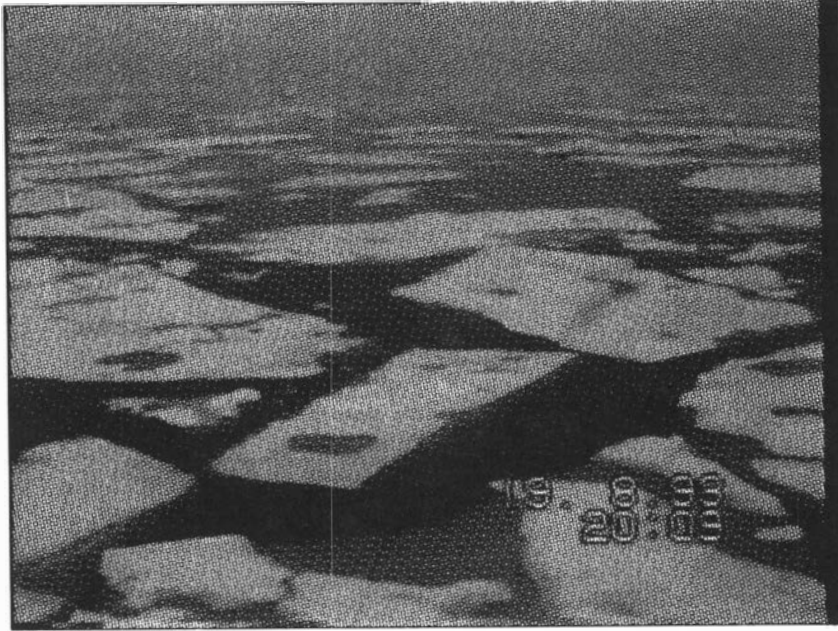

Fig. 3. Video image from the Lance crows nest at N78°57.58', W6°17.52' on 19 August 20:09 GMT.

## ANNEX I: Participants and affiliation

Name	Affiliation	Period
Torgny Vinje	NP	Leg I+II
Svein Østerhus	NP	Leg I+II
Øyvind Finnekåsa	NP	Leg I+II
Helene Moseidjord	GI/UiB	Leg I+II
Tore Furevik	GI/UiB	Leg I+II
Jo Høkedal	NP	Leg I+II
Alexander P. Makshtas	AARI	Leg I
Igor Kovtchin	INTAARI	Leg I
Sergey Unovidov	AARI	Leg I
Siri M.Kalvig	GI/UiB-NP	Leg I
Tor de Lange	GI/UiB-NP	Leg I
Reinert Korsnes	NP	Leg II
Fridtjof Mehlum	NP	Leg II
Morten Bilet	NP	Leg II
Megumi Ohta	UiO-NP	Leg II
Einar Nygård	GI/UiB	Leg II
Shuhje Aoki	NIPR	Leg II
Hajime Ito	NIPR	Leg II
Shinje Morimoto	NIPR	Leg II
Tobias Böhme	AWI	Leg II

### Addresses and teleconnections:

AARI: Arctic and Antarctic Research Institute, Bering str 38, 199397 St. Petersburg.  
Tel: + 7 812352 0319, Fax: + 7 812352 2688, E-mail: aaricoop@sovam.com

AWI: Alfred-Wegener-Institute for Marine and Polar Research, Bremerhaven  
Tel: + 49 4714831336, Fax: + 49 4714831149

GI/UiB: Geophysical Institute, University of Bergen, N-5007 Bergen  
Tel: + 47 55262107, Fax: + 47 55960566, E-mail: svein@gfi.uib.no

INTAARI: INTAARI Joint Enterprise, Bering str 38, 199397 St. Petersburg.  
Tel: + 7 8123523757, Fax: + 7 8123521691, E-mail: chiv@intar.spb.su

NP: Norsk Polarinstitutt, Box 5072, Majorstua, N-0301 Oslo.  
Tel. + 47 22959500, Fax: + 47 22959501, E-mail: vinje@npolar.no

NIPR: National Institute of Polar Research, Kaga 1-9-10, Itabashi, Tokyo 173.  
Tel: + 81 339624711, Fax: + 81 339625701

UiO: University of Oslo, Biological Institute, Box 1069-Blindern, 0316 Oslo.  
Tel: + 47 22854530, Fax: + 47 22854438



# ANNEX II: CTD-STATIONS IN THE GREENLAND SEA (UPPER) AND CTD-STATIONS AND MOORING IN THE BARENTS SEA.

